



INTERNATIONAL CANOE FEDERATION

# CANOE POLO COMPETITION RULES

# 2007

Taking effect from January 14<sup>th</sup>, 2007

## APPENDIX II - SCRUTINEERING

### 101. KAYAK – GENERAL

[TR]

101.1. A canoe polo kayak with integrated bumpers, or a kayak to have padding fixed later, must not be longer than 3000 mm and must not be wider than 600 mm.

101.2. Front and rear 'impact zones' must be rounded and padded as these rules so as to not cause injury to other players and to reduce/prevent damage to their equipment. For kayaks with integrated padding the length of the kayak will be measured with the padding in place.

101.3. The weight, including padding, may not be less than 7kg.

101.4. There may be no sharp projections or edges. All curves must stay within these rules.

101.5. Padding as in these rules, must be firmly fixed to the front and rear of the kayak.

101.6. The kayak will be scrutinized with gauges.

101.7. All references to plan, side, section, zones ends and axis refer to the kayak as set up in a normal position, and remaining in the same position for all measurements.

101.8. Kayak-Safety requirements

101.8.1. The kayak may have no sharp projections or edges or other dangerous features. For glass (composite) kayaks, all metal bolts, screws or other fixing devices should have low profile parts on the

surface, be smooth to the touch and be recessed wherever possible. Concave sections are allowable throughout the kayak so long as they do not present themselves as a dangerous feature. All metal bolts, screws or other fixing devices present in plastic kayaks must be recessed. Carry handles of any type are not permitted.

101.8.2. The kayak must have soft, shock absorbing material firmly affixed to the front and rear impact ends, sufficient to prevent injury to players and to reduce damage to equipment. The padding must comply with the detailed specifications.

101.8.3. The kayak must have sufficient buoyancy to keep it afloat, so that some part breaks the surface of the water, even when it is completely full of water.

101.9. KAYAK PLAN VIEW OF SECTIONS/ZONES

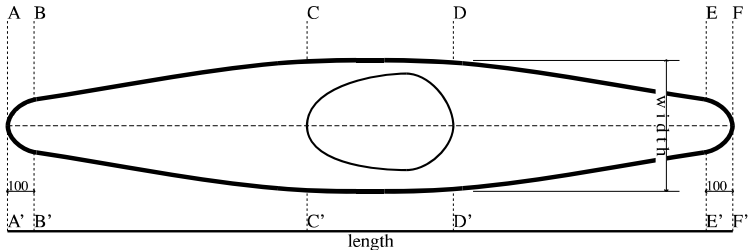

- Length: Maximum 3000 mm
- Width: Maximum 600 mm
- Section AA' to BB' - Front Impact Zone 100 mm minimum radius at any point on B-A-B'
- Section BB' to CC' - Front Section
- Section CC' to DD' - Cockpit Section
- Section DD' to EE' - Rear Section
- Section EE' to FF' - Rear Impact Zone 100 mm minimum radius at any point on E-F-E'

## 101.10. Kayak - Edge

101.10.1. The edge, is the line around the kayak (not necessarily the join or gunwale line) where the side or end meets the vertical tangent. References to the top, upper, lower or bottom of a kayak are relative to this edge.

101.10.2. The edge of the kayak must be of sufficient radius so as not to cause injury to a player on impact.

101.10.3. In profile, the minimum radius of curvature for the edge in each section is detailed in the following paragraphs.

101.10.4. In plan, the minimum radius of convex curvature for the edge is 100 mm throughout the edge of the kayak.

## 101.11. Kayak - Shape in Plan

101.11.1. In both front and rear impact zones, the minimum radius of convex curvature allowed is 100 mm. A minimum width of 200 mm within the first 100 mm must be reached. This first 100 mm is measured from the back of the padding against the kayak.

## 101.12. Kayak-Top and Bottom surface

101.12.1. The top and bottom surfaces including impact zones (excluding those parts of the cockpit covered by a spray deck) must be smooth so as not to cause injury to a player.

101.12.2. Top Surface in profile: Minimum radius of convex curvature allowed in the top surface of the impact zone is 20 mm.

101.12.3. Section AA' to FF' - the entire length of the kayak top, edge and bottom surface in profile. For the part 20mm measured vertically above the edge (point Y), and for the bottom surface the minimum radius of curvature allowed is 30 mm. For scrutineering purposes when padding is in place, the kayak must reach a depth or thickness of 60 mm within 50 mm from the back of the padding.

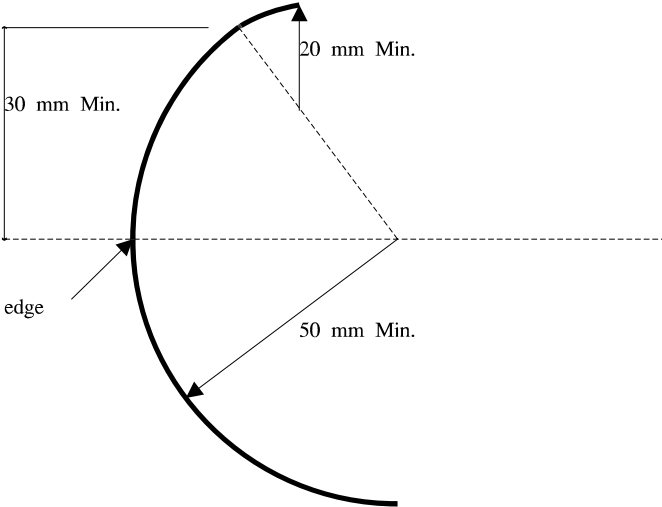

**101.12.4. For the top surface in profile the minimum radius of convex curvature allowed throughout the entire length of the kayak is 5 mm. (Section AA' to FF')**

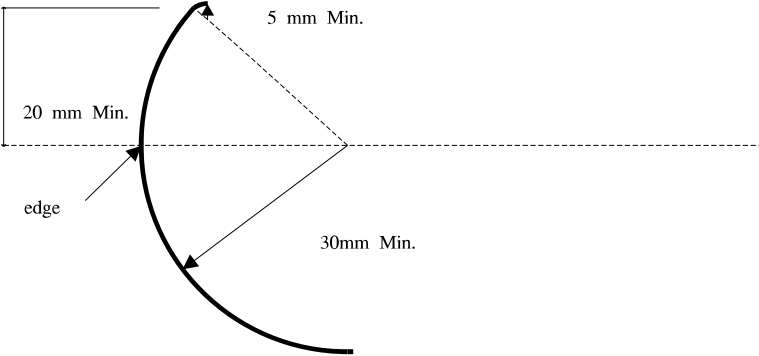

101.12.5. Recesses in the hull or deck for the purpose of hiding bolt or screw heads etc. are to be permitted. Recesses should be safer than a projecting fixing device in order to be legal. Where recesses are

provided to improve safety by eliminating projecting fixing devices, the 5mm radius shall be relaxed as far as it would cover the radius of any transition curve between the deck and the side surfaces of any such recess.

### 101.13. Kayak - Depth

101.13.1. The depth at the cockpit must be sufficient to provide some protection from impact for the player.

101.13.2. Throughout the length of the cockpit section of the kayak (from CC' to DD'), on each side of the cockpit, the kayak must be at least 160 mm deep, as seen in profile, not including the cockpit edge.

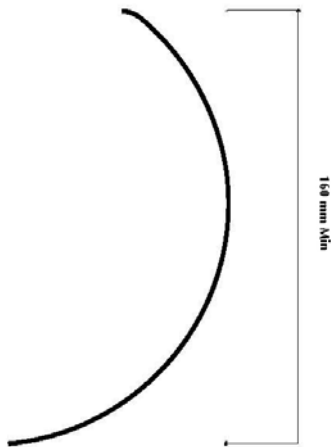

## 102. KAYAK GAUGES

[TR]

102.1. Standardised gauges are to be used to test compliance with the specifications. The gauges need to be from sheet aluminium and precisely engineered.

102.2. To gauge rise from the edge of the kayak, hold edge W-X of the gauge vertical and perpendicular to the kayak. Align 'edge mark' with the edge of the kayak. Side Y-Y' towards the kayak. Point Y indicates specified rise form the edge.

- If the 'edge mark' touches the edge, but point Y does not touch the kayak, then either the radius at that point is too small or does not rise high enough.
- If any points between Y and 'edge mark' on the kayak touch the gauge, but not both Y and 'edge mark', then the radius at that point is too small. If the kayak is exactly to minimum specification point Y and 'edge mark' and all points between will be touching.
- If both points Y and 'edge mark' touch, but no points between, then the radius at the 'edge mark' must be too small.

If that portion of the kayak being tested in general is of more than sufficient radius, point Y will touch, but no other part. In this case the rise test is passed.

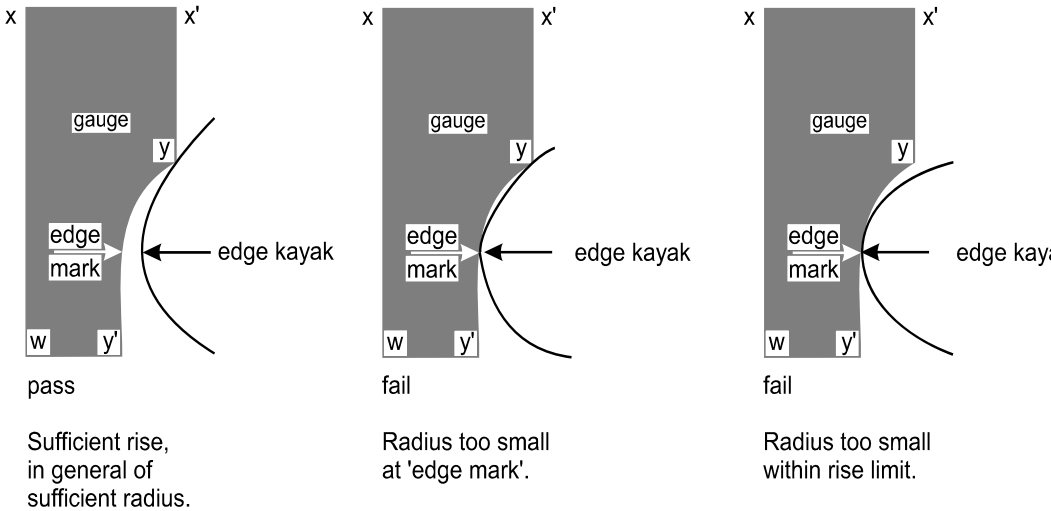

102.3. To gauge the radius of curvature the radius portion of the appropriate gauge, must be applied perpendicular to the surface being tested. If both

points X and X' touch the surface at the same time without the rest of the kayak, the test is passed.

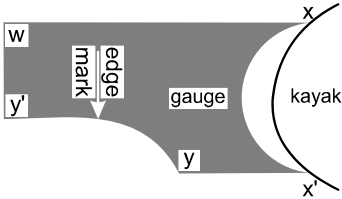

pass  
both points X and X' touch the surface

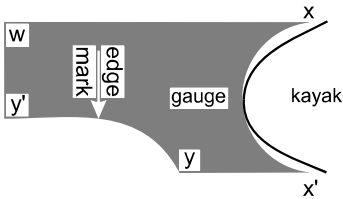

fail  
points X and X' do not touch the surface at the same time

102.4. The gauges to use for the measuring of the different sections are:

102.4.1. Gauge 1, edge gauge, 30 mm radius, 20 mm rise must be used to measure section AA' to FF' - entire length of kayak.

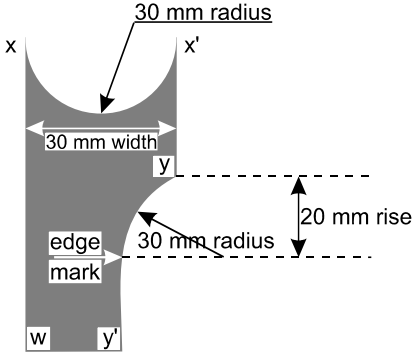

102.4.2. Gauge 2, Impact zone gauge, 100 mm radius, must be used to measure in plan sections AA' to BB' (front) and EE' to FF' (back).

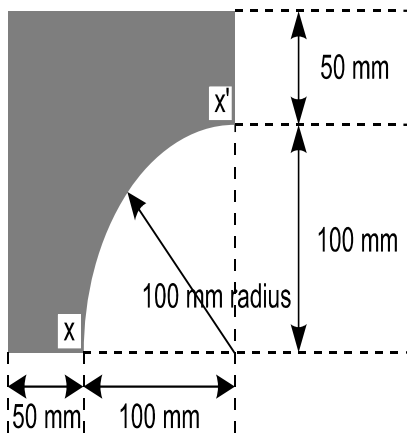

102.4.3. Gauge 3, depth gauge, 160 mm rise, must be used to measure section CC' to DD' (cockpit area).

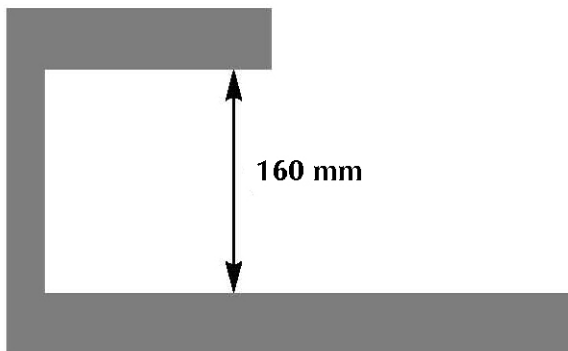

## 103. PADDING

[TR]

103.1. Canoe Polo kayaks with integrated bumpers cannot be longer than 3000 mm. Kayaks without integrated bumpers may be a maximum of 3100 mm once any padding is attached.

103.1.1. Soft shock absorbing padding a minimum of 30 mm thick (when uncompressed) at the horizontal centreline and 50 mm wide must be firmly attached to cover the edges of the front and back of the kayak

at the ends and extend at least 100 mm from the ends.

103.1.2. Soft shock absorbing material must be homogeneous (e.g.: foam, soft rubber). If it relies on a composite construction for its minimum thickness and shock absorbing property, then the essential shock absorbing property of the padding must not be lost under compression. The characteristics should be measured at the temperatures that will prevail during the competition.

103.1.3. The 30 mm thick must be reached on the horizontal centreline. It may be reduced to not less than 20 mm thick at a width of 50mm. The padding must be compressible (by a scrutineer's or player's thumb) by at least 10 mm. The padding must not be compressible to less than 10 mm thickness. The thickness and compression are measured parallel to the axis of the kayak.

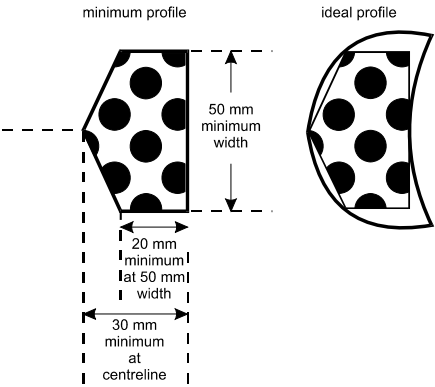

103.1.4. The padding must be positioned on the edge (see definition of edge in kayak specifications) to cover at least 15 mm above and below the edge.

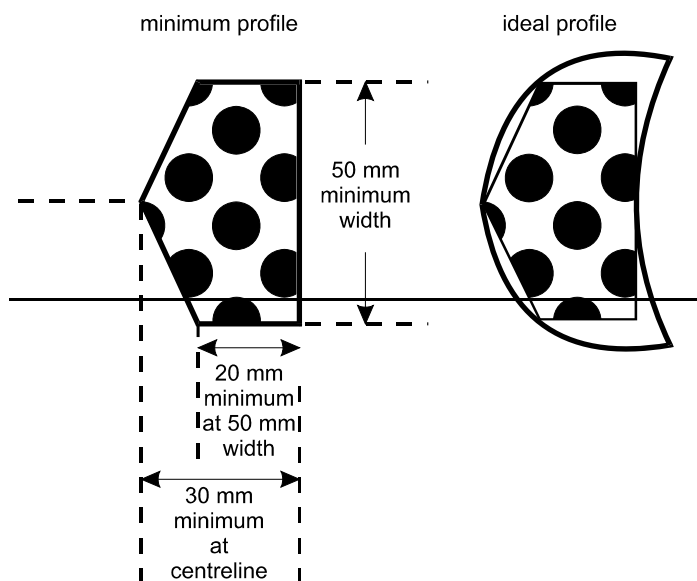

103.1.5. The padding must be attached in a way that the edges and ends are not, liable to catch on players or equipment. If tubing is used, the ends of the tubing must be closed or covered.

103.1.6. If rivets or bolts (or similar) are used to attach the padding, they must be recessed at least 20mm into the padding from the outer most part.

103.1.7. Any method of fitting should ensure there is no possibility of the bumper either falling off or out of position during the course of a competition.

103.1.8. For integrated bumpers there should be no (minimal) gap between the start/edge of the bumper and the part of the kayak to which it meets and any part of the kayak that meets the bumper should have a minimum of 5 mm radii.

103.1.9. The shape of the kayak beneath the integrated bumper is not important so long as while the bumper is in place the whole kayak meets the specifications outlined in this appendix.

103.1.10. For integrated bumpers in general their profile should so far as possible follow the profile of the kayak ends. The integrated bumper must be appropriate for that design of kayak.

## **104. PADDLE**

[TR]

104.1. The paddle must be double-bladed with no sharp projections, edges or other dangerous features. The blades shape, thickness and radii must stay within these rules. The paddle will be scrutineered with a gauge.

104.2. The blades are to be no more than 600 mm x 250 mm in plan measured from where the shaft meets the blade. The edges must have a minimum radius of 30 mm in plan and a minimum thickness of 5 mm. Metal tipped blades are not allowed.

104.3. The exception to this is those blades where the metal edge is an integral part of the construction as opposed to a rim or trim added to the outside by any means. However if at any point the internal metal component is exposed then it will be considered un-fit for use in canoe polo.

## **105. PADDLE GAUGE**

[TR]

105.1. A standardised gauge is to be used to test compliance with the specifications. The gauge needs to be from sheet aluminium and precisely engineered.

105.2. To gauge the radius of curvature the radius portion of the paddle gauge, must be applied perpendicular to the surface being tested. If both

points X and X' touch the surface at the same time without the rest of the paddle, the radius test is passed.

To gauge the thickness of the paddle-blade, hold the slot over the blade. If the paddle does not enter the slot, the test is passed.

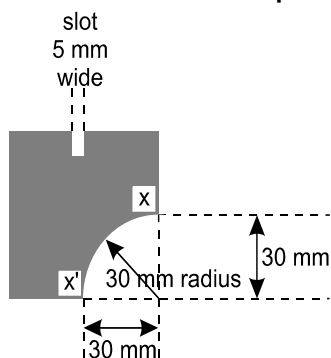

## 106. HELMET

[TR]

106.1. The helmet must be a safety one and suitable. They must protect against any blow, which may be reasonably anticipated in the course of a game covering from the jaw line to the rear point of the skull, such that no contact is possible between the skull and a blade on a horizontally held paddle.

## 107. FACE-PROTECTOR

[TR]

107.1. The face protector must be of a strong material such as steel or any equal strong material. In any part of the face protector, an object 70 mm cube must not be able to enter. The face protector must be securely fixed to the helmet, without sharp or dangerous fixings. They may not present any sharp or dangerous part. It must protect against any blow that may be reasonably anticipated in the course of a game. It must cover the entire face of the player

beginning at the lower level of the chin and covering the surface between the two temples.

## **108. BODY PROTECTION**

**[TR]**

108.1. The body protection must be at least 15 mm thick. They must protect against any impact from other players equipment, which may be reasonably anticipated in the course of a game. The body protection must begin no more than 100 mm above the cockpit rim measured at the player's side, with the player sitting normally in their kayak. The gap between the top of the protection at the side and the top of the armpit measured with the arm horizontal must be less than 100 mm.